



PERFORMANCE
POWER FILTER

AquaClear

FLUVAL

INSTRUCTION MANUAL

AC 110



FREE • GRATUIT • GRATIS • GRÁTIS

3 + 2
YEARS
ANS
JAHRE
AÑOS
ANOS

EXTENDED WARRANTY WITH ONLINE REGISTRATION
GARANTIE PROLONGÉE AVEC INSCRIPTION EN LIGNE
GARANTIEVERLÄNGERUNG MIT ONLINE-REGISTRIERUNG
GARANTIA ESTENDIDA AL REGISTRARTE ONLINE
GARANTIA ALARGADA CON REGISTRO ONLINE

WHAT'S INCLUDED

1. Filter Cover
2. Media Basket
3. Filter Case
4. Impeller Assembly
5. Seal Ring
6. Motor Unit
7. Levelling Device
8. Impeller Cover
9. Intake "U" Tube
10. Intake "U" Tube Adaptor
11. Extension Tube
12. Intake Stem
13. Intake Sponge
14. Bio-Foam
15. 2 x Carbon
16. 2 x BIOMAX

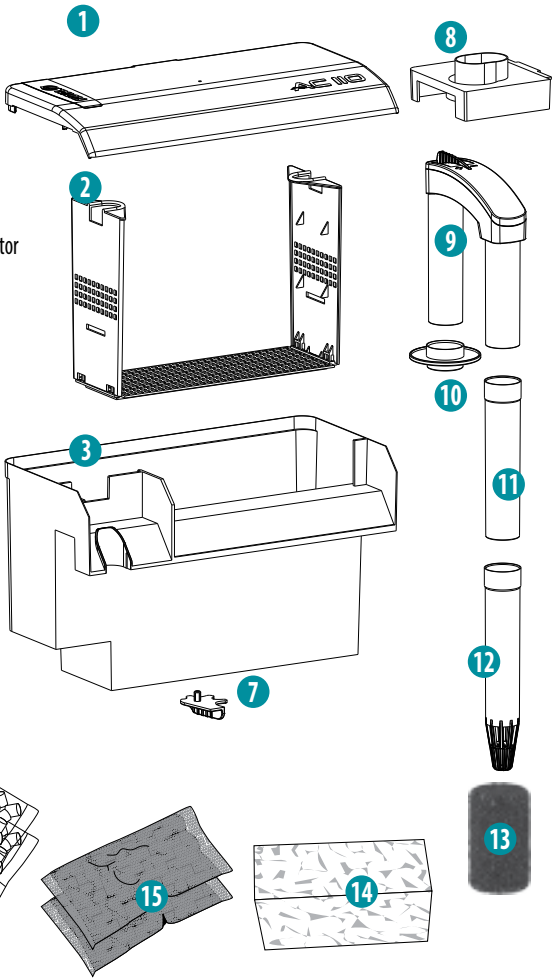

IMPORTANT SAFETY INSTRUCTIONS

WARNING—To guard against injury, basic safety precautions should be observed, including the following:

1. **READ AND FOLLOW ALL SAFETY INSTRUCTIONS**

and all important notices on the appliance before using. Failure to do so may result in damage to the appliance.

2. **DANGER – To avoid possible electrical shock, special care should be taken since water is employed in the use of this equipment. For each of the following situations, do not attempt repairs yourself; return the appliance to an authorized service facility for service or discard the appliance.**

- A. If the appliance falls into the water **DO NOT** reach for it! First unplug it and then retrieve it. If any of the electrical components of the appliance gets wet, unplug it immediately.
- B. If the appliance shows any sign of abnormal water leakage or if RCD (or GFCI- Ground Fault Current Interrupter) switches off disconnect the power supply cord from mains and remove pump from water.
- C. Carefully examine the appliance after installation. It should not be plugged in if there is water on parts not intended to be wet.
- D. Do not operate any appliance if it has a damaged cord or plug, or if it is malfunctioning or if it is dropped or damaged in any manner. The power cord of this appliance cannot be replaced; if the cord is damaged, the appliance should be discarded. Never cut the cord.
- E. To avoid the possibility of the appliance plug or receptacle getting wet, position the appliance to one side of a wall mounted receptacle to prevent water from dripping onto the receptacle or plug. A “drip loop” (A) should be arranged to the receptacle. The “drip loop” is the part of the cord below the level of the receptacle or the connector if an extension cord is used, to prevent water traveling along the cord and coming into contact with the receptacle. If the plug or receptacle does get wet, **DO NOT** unplug the cord. Disconnect the fuse or circuit breaker that supplies power to the appliance. Then unplug and examine for presence of water in the receptacle.



3. **WARNING** – Close supervision is necessary when any appliance is used by or near children. This appliance can be used by children ages 3 years and above and persons with reduced physical, sensory or mental capabilities or lack of experience and knowledge if they have been given supervision or instruction concerning use of the appliance in a safe way and understand the hazards involved. Children shall not play with the appliance. Cleaning and user maintenance shall not be made by children without supervision.
4. To avoid injury, do not contact moving parts or hot parts such as heaters, reflectors, lamp bulbs, and the like.
5. **CAUTION** – **Always unplug or disconnect all appliances in the aquarium from electricity supply before placing hands in water, before putting on or taking off parts and while the equipment is being installed, maintained or handled. Never yank cord to pull plug from outlet. Grasp the plug and pull to disconnect. Always unplug an appliance from an outlet when not in use.**
6. This appliance is a non-submersible aquarium filter-pump. It is intended for use in ornamental household aquariums. It may be used with fresh or salt water. Maximum water temperature 35°C. Do not use this appliance for other than intended use (ie: DO NOT use in swimming pools, bathtubs, etc.). The use of attachments not recommended or sold by the appliance manufacturer may cause an unsafe condition and will invalidate your warranty.
7. This is a **HOUSEHOLD APPLIANCE INTENDED FOR DOMESTIC USE** and it is suitable for INDOOR use only. Do not install or store this appliance where it will be exposed to the weather or temperatures below freezing.
8. Make sure that this appliance is securely installed before operating it and that the electrical connection is in accordance with the data on the rating label. Do not allow filter pump to run dry.
9. If an extension cord is necessary, a cord with a proper rating should be used. A cord rated for less amperes or watts than the appliance rating may overheat. Care should be taken to arrange the cord so that it will not be tripped over or pulled. The connection should be carried out by a qualified electrical installer.

10. **SAVE THESE INSTRUCTIONS** for future reference.

QUICK START GUIDE

1. Rinse filter media before use.
 - a. Rinse Bio-Foam thoroughly and place in bottom section of media basket.
 - b. Remove both Activated Carbon media from protective plastic bags. Rinse thoroughly and place both media horizontally on top of Bio-Foam.
 - c. Remove both BIOMAX media from protective plastic bags. Rinse thoroughly before placing both media on third level of basket.
2. Place the media basket into the filter case.

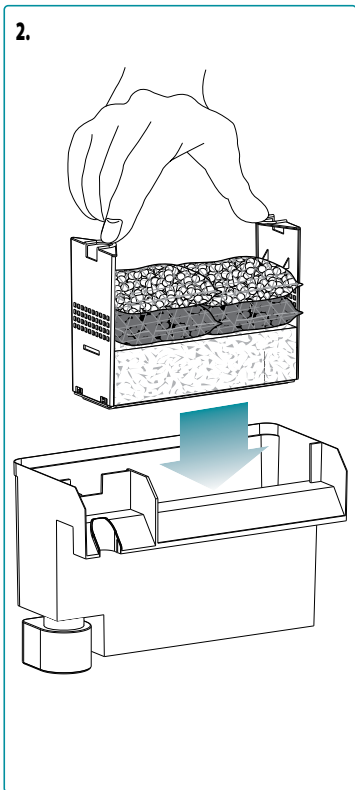
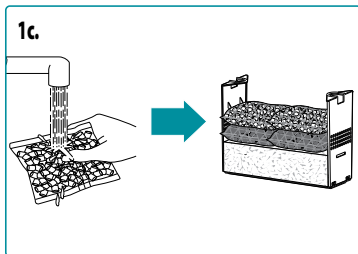
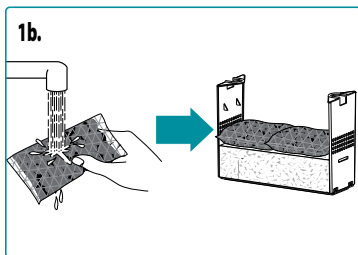
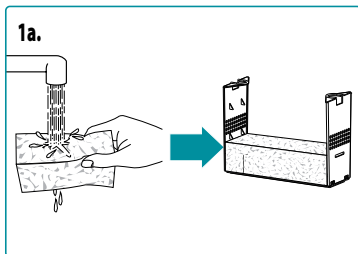

3. Install the intake "U" tube adaptor on the intake "U" tube.
4. Install the intake "U" tube and apply gentle pressure until it clicks into position.
5. Attach intake sponge to end of intake stem.
6. Add the extension tube to the intake stem if aquarium depth requires it.
7. Attach intake assembly to intake U tube and apply gentle pressure until it slides into position.
8. Attach levelling device to filter case by inserting peg into place.
9. Mount filter onto rear of aquarium.
10. Rotate levelling device until filter is perfectly level.

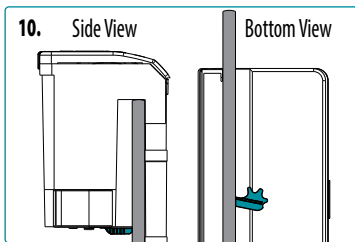
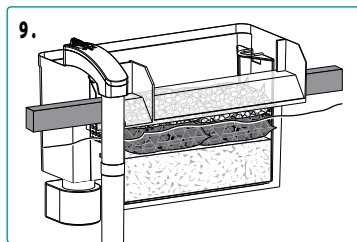
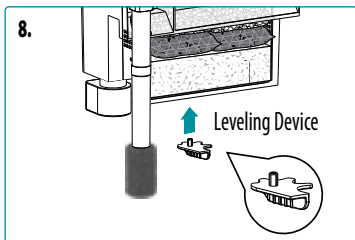
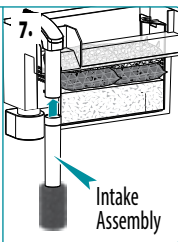
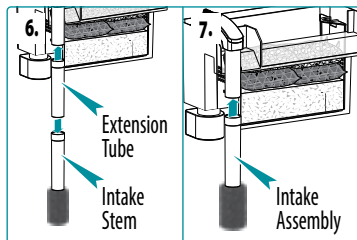
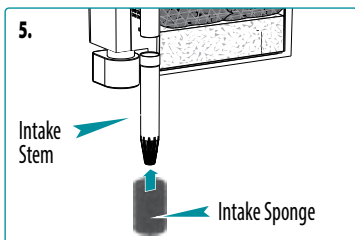
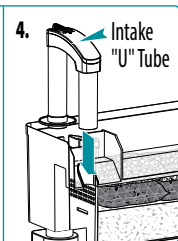
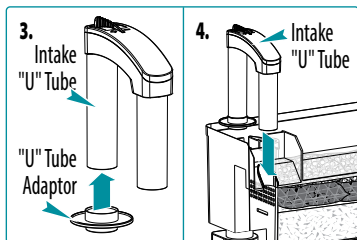

11. Fill filter case completely with water.
12. For the initial start-up and for a faster priming of filter, adjust water flow control lever on the intake "U" tube to its minimum position.
13. Plug power cord into electrical outlet. Allow 30-45 seconds for priming.
14. When priming is complete, adjust flow control to desired output.
15. Install filter cover.

IMPORTANT - DO NOT OPERATE FILTER WITHOUT WATER

For optimal filter operation and efficiency, regular cleaning of the filter and its parts is recommended every month. Do not use soaps or detergents.

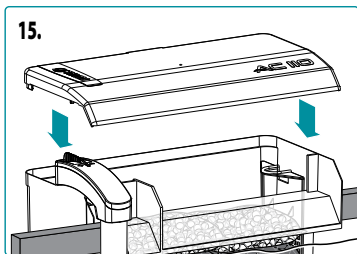
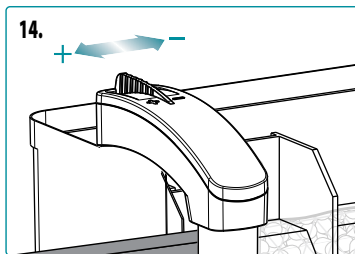
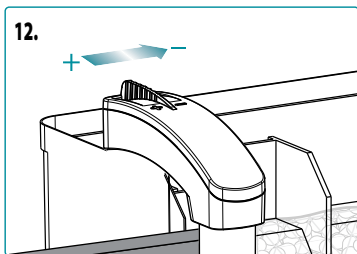
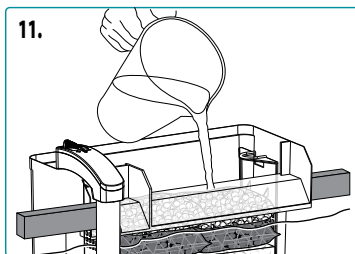

POWER FILTER MAINTENANCE

Always unplug power filter prior to cleaning. Remove cover, filter basket, and discard water remaining in the filter case. Thoroughly rinse collected debris from the case, impeller cover and impeller assembly in clear lukewarm water. The intake "U" tube and extension tube can be cleaned with a filter stem brush to remove any buildup of deposits. When all parts have been cleaned and thoroughly rinsed, reassemble filter and replace onto aquarium. Follow operating instructions to restart and prime power filter.

(See Quick Start Guide)

Every three months the motor should be thoroughly cleaned. Remove filter cover, filter basket and discard water remaining in filter case.

1. Remove motor by twisting a $\frac{1}{4}$ -turn gently in the direction of the arrow on front. Ease motor down slowly to prevent damage to the filter and motor guide.
2. Pull impeller out of impeller well and rinse to remove accumulated slime deposits.
3. A cotton swab or impeller well brush can be used to remove more stubborn deposits. Place impeller back into position.
4. Reinstall motor.

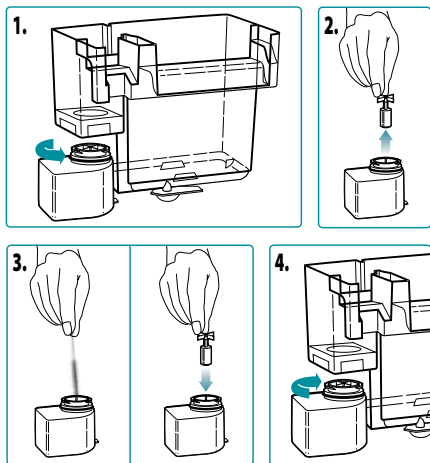

MAINTENANCE FREQUENCY CHART

COMPONENTS	MONTHLY	EVERY 2 MONTHS	EVERY 3 MONTHS
Impeller			Check & Clean
Seal Ring			Check & Clean
Bio-Foam	Check & Clean	Replace	
BIOMAX	Rinse		Replace
Carbon Insert	Replace		

SPARE PARTS

AC110						
DESCRIPTION	1. Filter Cover	2. Media Basket	3. Filter Case	4. Impeller Assembly	5. Seal Ring	6. Motor Unit
ITEM No.	A16431	A16440	A16420	A638	A16417	A16400

AC110					
DESCRIPTION	7. Leveling Device	8. Impeller Cover	9. Intake "U" tube	11. Extension Tube	12. Intake Stem
ITEM No.	A16325	A16415	A16351	A16353	A16352

TROUBLE SHOOTING & FAQ

- Q. What is the maximum aquarium rim thickness this filter can fit on?**
- A. The maximum aquarium rim size for AC20, AC30, AC50 and AC70 filters is 0.9" / 2.4 cm. In the case of the AC110, it is 1.4" / 3.6 cm.
- Q. How does water flow through an AC Series filter?**
- A. Water enters the filter via the intake tubes and travels to the bottom of the filter case. It then passes through the Bio-Foam, Carbon and BIOMAX before returning to the aquarium. When the flow control lever is set to its minimum position, up to 50% of the water is recirculated for slower but more thorough filtration.
- Q. What is the minimum aquarium water level required for AC Series filters to work properly?**
- A. For AC20, AC30 and AC50 filters, the water level should be no more than 5/8" / 16 mm from the bottom of the filter output. For AC70 and AC110 filters, the water level should be no more than 1.5" / 38 mm from the bottom of the filter output.
- Q. My filter is not starting. What should I do?**
- A. First, verify that the electrical cord is accurately plugged into a power outlet. Next, ensure that the filter container is completely filled with water and that the filter intake stem (U-shaped tube) is properly seated on the impeller cover. Also verify that the impeller, impeller shaft and impeller well are thoroughly cleaned and free of debris.
- Q. Should I use one or both of the included intake stems?**
- A. We recommend using as many of the intake stems as will fit in your aquarium. Drawing water from deeper in the aquarium guarantees the most efficient filtration overall.
- Q. What is the best way to prime an AC Series filter?**
- A. First, ensure the filter case is completely filled with water, and adjust the water flow control lever to its lowest setting for initial start-up. Plug the power cord into the electrical outlet and allow 30-45 seconds for priming. After priming has been completed, you can adjust the water flow control lever as required.

TROUBLE SHOOTING & FAQ

- Q. The water level in my AC Series filter is quite high and there is water spilling over into the aquarium on the intake side. Why is this happening?**
- A. This is likely occurring as a result of the filter media being clogged and not allowing water to pass through efficiently. Rinse out the media on a regular basis to help prevent this from happening.
- Q. The flow of water out of my AC Series filter is slower than normal. Why?**
- A. It's likely the media is dirty and in need of cleaning / replacement. It's also possible the impeller assembly needs to be cleaned, or the impeller needs to be replaced.
- Q. How frequently should I clean the intake strainer sponge?**
- A. We recommend rinsing the intake strainer sponge monthly and replacing it every two months. However, more frequent rinsing may be necessary depending on your particular aquarium.
- Q. Why is my filter making noise?**
- A. Noise originating from the motor suggests that the impeller assembly needs to be cleaned. Unplug the filter from the power source, empty the water from the container, remove the motor and thoroughly clean all parts to ensure the impeller assembly is free of debris. It is also possible the impeller assembly is in need of replacement: as the only moving part in the filter that operates 24 hours/day, the impeller does eventually wear and is therefore not covered under warranty.
- Q. How do I remove surface film from my aquarium water?**
- A. A surface film can be the result of cooking smoke, skin oils, dust accumulation, and fish food, which naturally includes fat content. We recommend the use of the Fluval AC Series Surface Skimmer connected to the intake of your filter.

RECYCLING



This product bears the selective sorting symbol for waste electrical and electronic equipment (WEEE). This means that this product must be handled pursuant to European Directive 2012/19/EU in order to be recycled or dismantled to minimize its impact on the environment. Check with your local Environmental Agency for possible disposal instructions or take to an official council registered refuse collection point. **Electronic products not included in the selective sorting process are potentially dangerous for the environment and human health due to the presence of hazardous substances.**

FOR AUTHORIZED WARRANTY REPAIR SERVICE

QUESTIONS? If you have a problem or question about the operation of this product, please let us try to help you before you return the product to your dealer. Most problems can be handled promptly with a phone call. Or, if you prefer, you can contact us on our website at www.fluvalaquatics.com. When you call (or write), please have all relevant information, such as model number and/or part numbers available.

USA CALL US ON OUR TOLL-FREE NUMBER: 1-800-724-2436 between 9:00 a.m. and 4:00 p.m. Eastern Standard Time. Ask for Customer Service.

CANADA CALL US ON OUR TOLL-FREE NUMBER: 1-800-554-2436 between 8:00 a.m. and 4:30 p.m. Eastern Standard Time. Ask for Customer Service.

UK Helpline Number 01977 521015. Between 9:00 a.m. and 5:00 p.m., Monday to Thursday and 9:00 a.m. and 4:00 p.m. on Friday (excluding Bank Holidays).

3 YEAR WARRANTY

The Fluval AquaClear or AC Series filter is guaranteed for defective parts and workmanship for a period of 3 years from the date of purchase. This guarantee is valid with proof of purchase only. The guarantee is limited to repair or replacement only and does not cover consequential loss, loss or damage to livestock and personal property or damage to animate or inanimate objects, irrespective of the cause thereof. This guarantee is valid only under normal operating conditions for which the unit is intended. It excludes any damage caused by unreasonable use, negligence, improper installation, tampering, abuse or commercial use. The warranty does not cover wear and tear, breakage of glass or parts which have not been adequately or correctly maintained. **THIS DOES NOT AFFECT YOUR STATUTORY RIGHTS.**

BONUS +2 YEARS EXTENDED WARRANTY

LIMITED TIME OFFER! Register this product online within 30 days of purchase and Fluval will extend your current warranty at no charge. The extended warranty is subject to provisions outlined within the standard Fluval warranty. Complete details and registration available at:

FluvalAquatics.com/warranty

